

2011 DUPONT DR. SNEED SHIPBUILDING ORANGE TX. 77630	
SCALE: NA	CHK'D J. BARRETT DRAWN: M. ROY
DATE: 05-25-2010	JOB NO.: DB-97 REV: 3
"CBC-763" - DB-97 180'X54'X12' General Arrangement	
CUSTOMER: Canal Barge Company	FILE NAME: DB-97 SHEET: 1 of 1

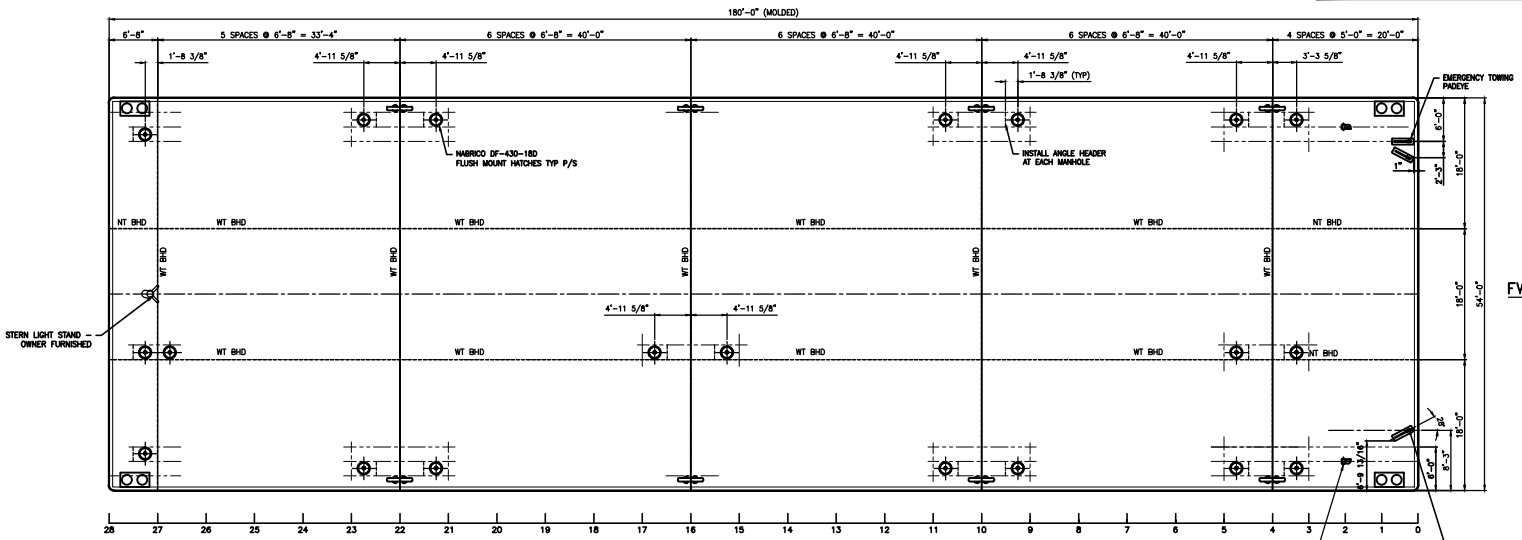

DECK PLAN
SCALE: 1/8"=1'-0"

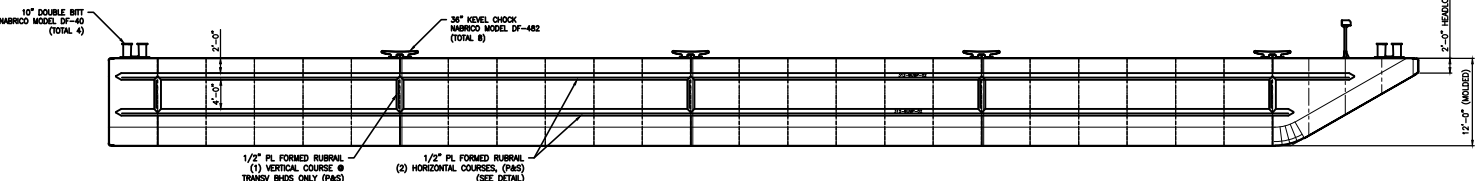

OUTBOARD PROFILE
SCALE: 1/8"=1'-0"

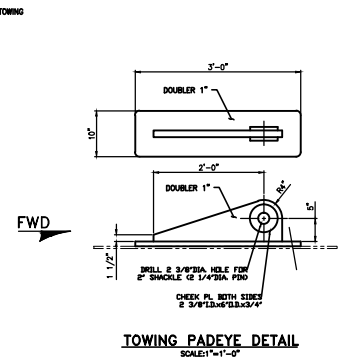

TOWING PAD EYE DETAIL
SCALE: 1"=1'-0"

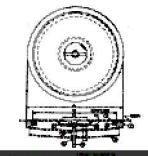

NO.	DESCRIPTION	QTY	UNIT	REMARKS
1
2
3
4
5
6
7
8
9
10

NABRICO DF-430-18D